

SKY CASTER

專業腳輪製造

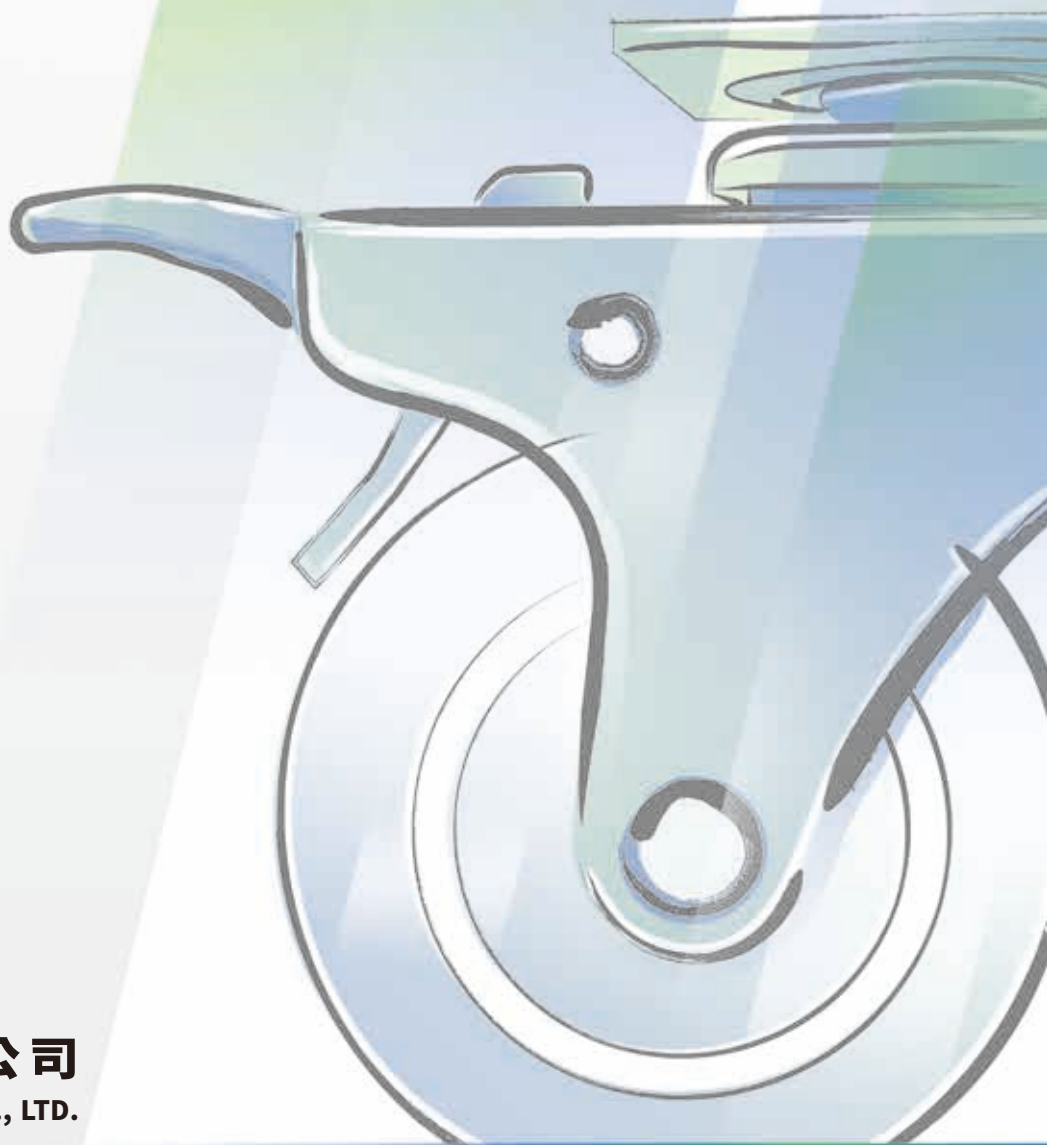

仲恩國際有限公司
ERICON INTERNATIONAL CO., LTD.

專業製造 品質至上

堅持只做好產品





1.2" 尼龍輪



NW-1



NW-2



NW-3



N-2



N-1



N-3

▶ 產品說明：

產品名稱：1.2" 尼龍輪









輪架結構：鋼珠轉盤

輪子材質：尼龍

輪子顏色：白、灰

適用範圍：傢具設備、椅子、賣場展示架、
小型機櫃、電腦主機架、醫療儀
器及設備

產品特點：耐磨、美觀、移動輕巧

型號	 輪徑 (mm)	 輪寬 (mm)	 平板規格 (mm)	 平板孔距 (mm)	 孔徑 (mm)	 螺牙尺寸 (mm)	 總高度 (mm)	 載重量 (kg)
NW-1	31	19	42.2	28.5	5		44	30
NW-2								
NW-3								
N-1								
N-2								
N-3								

1.5" 透明輪



▶ 產品說明：





- 產品名稱：1.5" 透明輪
- 輪架結構：鋼珠轉盤
- 輪子材質：PVC(RoHS)
- 輪子顏色：透明黃、灰
- 適用範圍：傢具設備、椅子、賣場展示架、
小型機櫃、電腦主機架、醫療儀
器及設備
- 產品特點：耐磨、移動輕巧、美觀

Available Wheel



Yellow,Bearing

Gray,Bearing

型號	 輪徑 (mm)	 輪寬 (mm)	 平板規格 (mm)	 平板孔距 (mm)	 孔徑 (mm)	 螺牙尺寸 (mm)	 總高度 (mm)	 載重量 (kg)
A-1	38.5	24	50x50	37x37	6		55.5	40
A-2								
A-3								
A-4								
A-5						3/8x19	58	



2" 透明輪



B-1



B-2



B-3



B-4



B-5

▶ 產品說明：

- 產品名稱：2" 透明輪
- 輪架結構：鋼珠轉盤
- 輪子材質：PVC(RoHS)
- 輪子顏色：透明黃、黑
- 適用範圍：椅子、賣場展示架、傢具設備、展示櫃、小型機櫃、電腦主機架、醫療儀器及設備
- 產品特點：耐磨、移動輕巧、美觀









Available Wheel



Yellow,Bearing



Black,Bearing

型號	 輪徑 (mm)	 輪寬 (mm)	 平板規格 (mm)	 平板孔距 (mm)	 孔徑 (mm)	 螺牙尺寸 (mm)	 總高度 (mm)	 載重量 (kg)
B-1	50	24	50x50	37x37	6	3/8x19	66	40
B-2								
B-3								
B-4								
B-5								

2"

透明培林輪



BF-1



BF-2



BF-3



BF-5

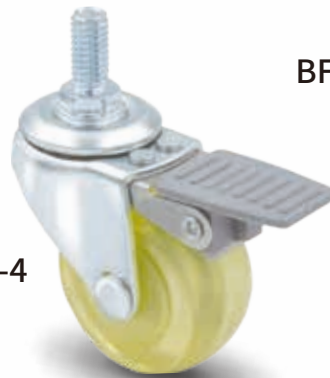

BF-4

▶ 產品說明：

產品名稱：2" 透明培林輪

輪架結構：鋼珠轉盤









輪子材質：PVC(RoHS)(精密培林)

輪子顏色：透明黃

適用範圍：椅子、賣場展示架、傢具設備、展示櫃、小型機櫃、電腦主機架、醫療儀器及設備

產品特點：★ 輪軸採 608 單一精密培林，移動輕巧滑順

★ 輪子兩側均有防塵蓋，防止細屑、粉塵侵入

型號	 輪徑 (mm)	 輪寬 (mm)	 平板規格 (mm)	 平板孔距 (mm)	 孔徑 (mm)	 螺牙尺寸 (mm)	 總高度 (mm)	 載重量 (kg)
BF-1	50	23	50x50	37x37	6	3/8x19	66	40
BF-2								
BF-3								
BF-4								
BF-5								



2"

TPR 靜音輪



▶ 產品說明：

產品名稱：2"TPR 靜音輪

輪架結構：鋼珠轉盤







輪子材質：高彈性 TPR(精密培林)

輪子顏色：灰

適用範圍：椅子、賣場展示架、傢具設備、展示櫃、小型機櫃、電腦主機架、點滴架、醫療器材

產品特點：★ 輪軸採 608 單一精密培林，移動輕巧滑順、安靜、不傷地板

★ 輪子兩側均有防塵蓋，防止細屑、粉塵侵入

型號	 輪徑 (mm)	 輪寬 (mm)	 平板規格 (mm)	 平板孔距 (mm)	 孔徑 (mm)	 螺牙尺寸 (mm)	 總高度 (mm)	 載重量 (kg)
BR-1	50	23	50x50	37x37	6	3/8x19	66.5	40
BR-2								
BR-3								
BR-4								
BR-5								

2"

電鍍塗著輪



▶ 產品說明：

- 產品名稱：2" 電鍍塗著輪
- 輪架結構：精密培林轉盤
- 輪子材質：PVC(RoHS)、高彈性 TPR(精密培林)
- 輪子顏色：黑
- 適用範圍：傢具設備、辦公椅、賣場展示架、展示櫃、黑色製品、工作桌
- 產品特點：
 - ★ 輪軸採 608 單一精密培林，移動輕巧滑順
 - ★ TPR 材質，移動安靜，不傷地板
 - ★ 電鍍塗著不易生銹
 - ★ 輪子兩側均有防塵蓋，防止細屑、粉塵侵入

Available Wheel

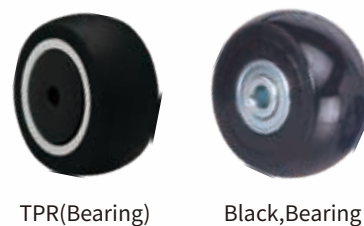

型號	輪徑 (mm)	輪寬 (mm)	平板規格 (mm)	平板孔距 (mm)	孔徑 (mm)	螺牙尺寸 (mm)	總高度 (mm)	載重量 (kg)
BS-1	50	23	50.5x50.5	38x38	6		68.5	40
BS-2								
BS-3								
BS-4								
BS-5						3/8x19	70	



2.5" TPR 尼龍靜音輪



▶ 產品說明：

產品名稱：2.5"TPR 尼龍靜音輪

輪架結構：玻璃纖維填充尼龍腳架 + 精密培林轉盤

輪子材質：高彈性 TPR(精密培林)

輪子顏色：黑









適用範圍：傢具設備、辦公椅、賣場展示架、展示櫃、點滴架、醫療設備、小型機櫃

產品特點：★ 培林轉盤設計，旋轉及移動輕巧、安靜

★ 輪架具有高度吸收衝擊的能力

★ 防水、安靜、不傷地板、美觀使用壽命長

★ 輪子側蓋有防卡毛屑設計，不會因卡毛屑而影響輪子功能

型號	 輪徑 (mm)	 輪寬 (mm)	 平板規格 (mm)	 平板孔距 (mm)	 孔徑 (mm)	 螺牙尺寸 (mm)	 總高度 (mm)	 載重量 (kg)
NB-1	65	21	50.8x50.8	38.5x38.5	6		94.5	50
NB-2							96	
NB-3							96	
NB-4			3/8 x 19	96				
NB-5			11 x 22	93				
NB-6			11 x 22	93				

2.5" TPR 靜音輪



▶ 產品說明：

產品名稱：2.5"TPR 靜音輪

輪架結構：鋼珠轉盤





輪子材質：高彈性 TPR(精密培林)

輪子顏色：灰

適用範圍：傢具設備、辦公椅、賣場展示架、展示櫃、點滴架、醫療設備

產品特點：★ 移動安靜、輕巧、不傷地板

★ 輪子兩側均有防塵蓋，防止細屑、粉塵侵入

型號	 輪徑 (mm)	 輪寬 (mm)	 平板規格 (mm)	 平板孔距 (mm)	 孔徑 (mm)	 螺牙尺寸 (mm)	 總高度 (mm)	 載重量 (kg)
CR-1	65	21	50x50	37x37	6		82	50
CR-2								
CR-3								
CR-4						3/8x19	86.5	
CR-5								



2.5" A版 TPR/PU 儀器輪



▶ 產品說明：

產品名稱：2.5" A版 TPR/PU 儀器輪

輪架結構：精密培林轉盤









輪子材質：高彈性 TPR、PU

輪子顏色：灰

適用範圍：傢具設備、賣場展示架、展示櫃、賣場花車、電腦機櫃、電腦主機架、點滴架、醫療儀器及醫療設備

產品特點：★ 移動安靜、輕巧、不傷地板

★ 雙踏板式剎車，操作便利

型號	 輪徑 (mm)	 輪寬 (mm)	 平板規格 (mm)	 平板孔距 (mm)	 孔徑 (mm)	 螺牙尺寸 (mm)	 總高度 (mm)	 載重量 (kg)
C-1	61	28	72x60	55x40	11x8	1/2 & 3/8 x 25	90	50
C-2								
C-3								
C-4								
C-5								

3"

A 版 TPR 儀器輪

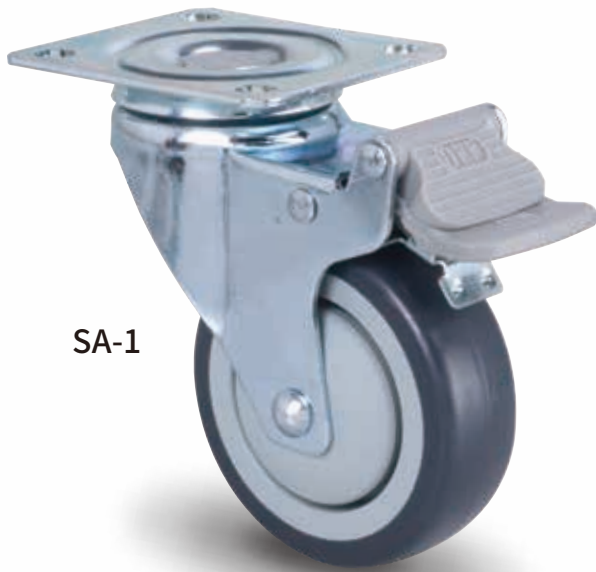

SA-1



SA-2



SA-3



SA-4



SA-5

▶ 產品說明：

產品名稱：3"A 版 TPR 儀器輪

輪架結構：精密培林轉盤

輪子材質：高彈性 TPR

輪子顏色：灰

適用範圍：賣場展示架、展示櫃、電腦機櫃、點滴架、
餐飲設備、食品機械設備、自動化設備、
精密儀器設備、運輸設備、賣場推車

產品特點：★ 移動安靜、輕巧、不傷地板

★ 輪子兩側均有防塵蓋，防止細屑、粉塵侵入

★ 雙踏板式剎車，操作便利

Available Wheel



ESD



TPR(Bearing)



TPR

型號	輪徑 (mm)	輪寬 (mm)	平板規格 (mm)	平板孔距 (mm)	孔徑 (mm)	螺牙尺寸 (mm)	總高度 (mm)	載重量 (kg)
SA-1	75	25	75.7x65	57x47	8	1/2 & 3/8 x 25	108	50
SA-2								
SA-3								
SA-4								
SA-5								



3"

B 版 TPR 儀器輪

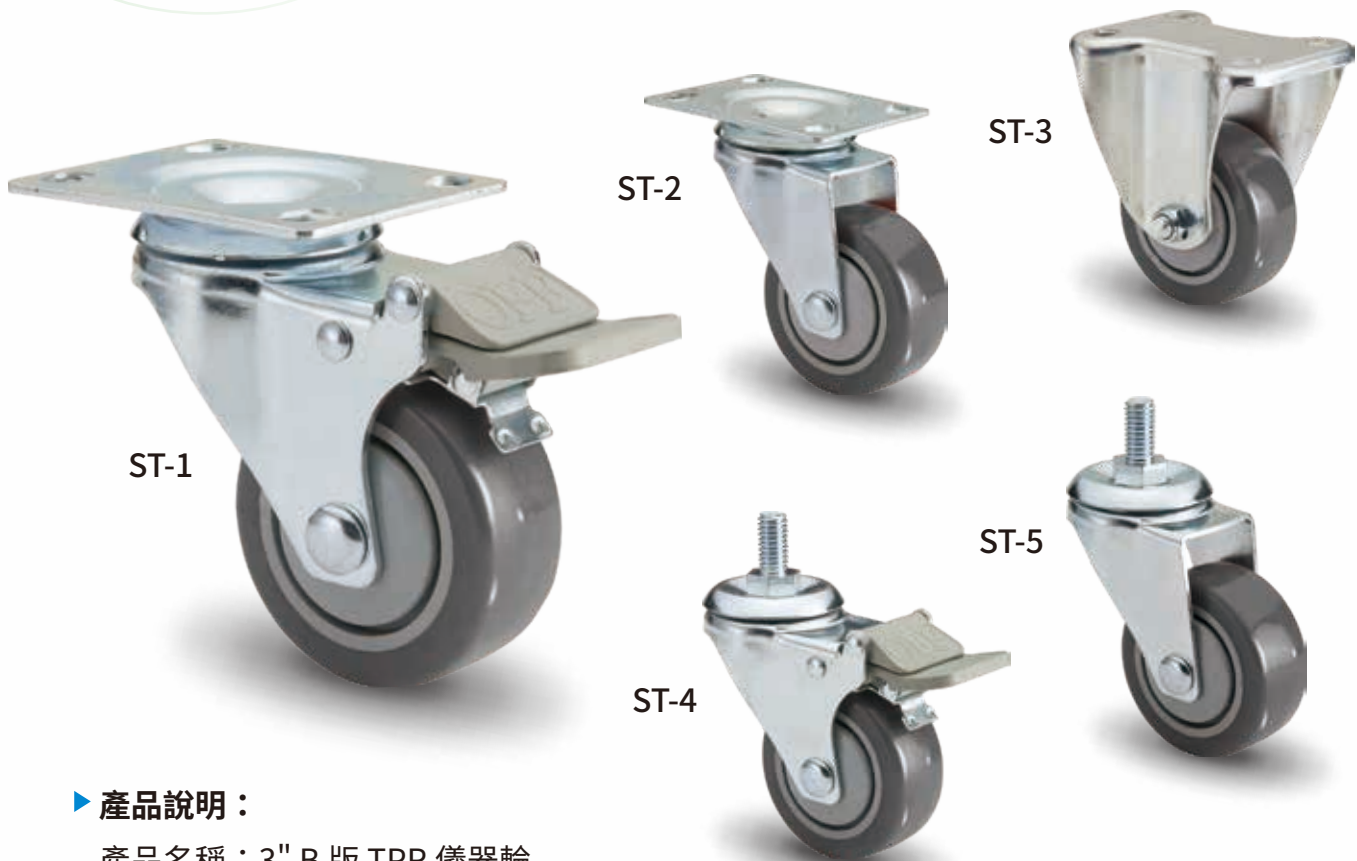

▶ 產品說明：

產品名稱：3" B 版 TPR 儀器輪

輪架結構：精密培林轉盤

輪子材質：高彈性 TPR(精密培林)









輪子顏色：灰

適用範圍：角鋼、電腦機櫃、餐飲設備、食品機械設備、自動化設備、精密儀器設備、運輸設備、賣場推車、各式手推車

產品特點：★ 移動安靜、輕巧、不傷地板

★ 輪子兩側均有防塵蓋，防止細屑、粉塵侵入

★ 雙踏板式剎車，操作便利

型號	 輪徑 (mm)	 輪寬 (mm)	 平板規格 (mm)	 平板孔距 (mm)	 孔徑 (mm)	 螺牙尺寸 (mm)	 總高度 (mm)	 載重量 (kg)
ST-1	75	31	93.5x75	73x49	14x10	1/2 x 25	114	70
ST-2								
ST-3								
ST-4								
ST-5								

4"

TPR 儀器輪

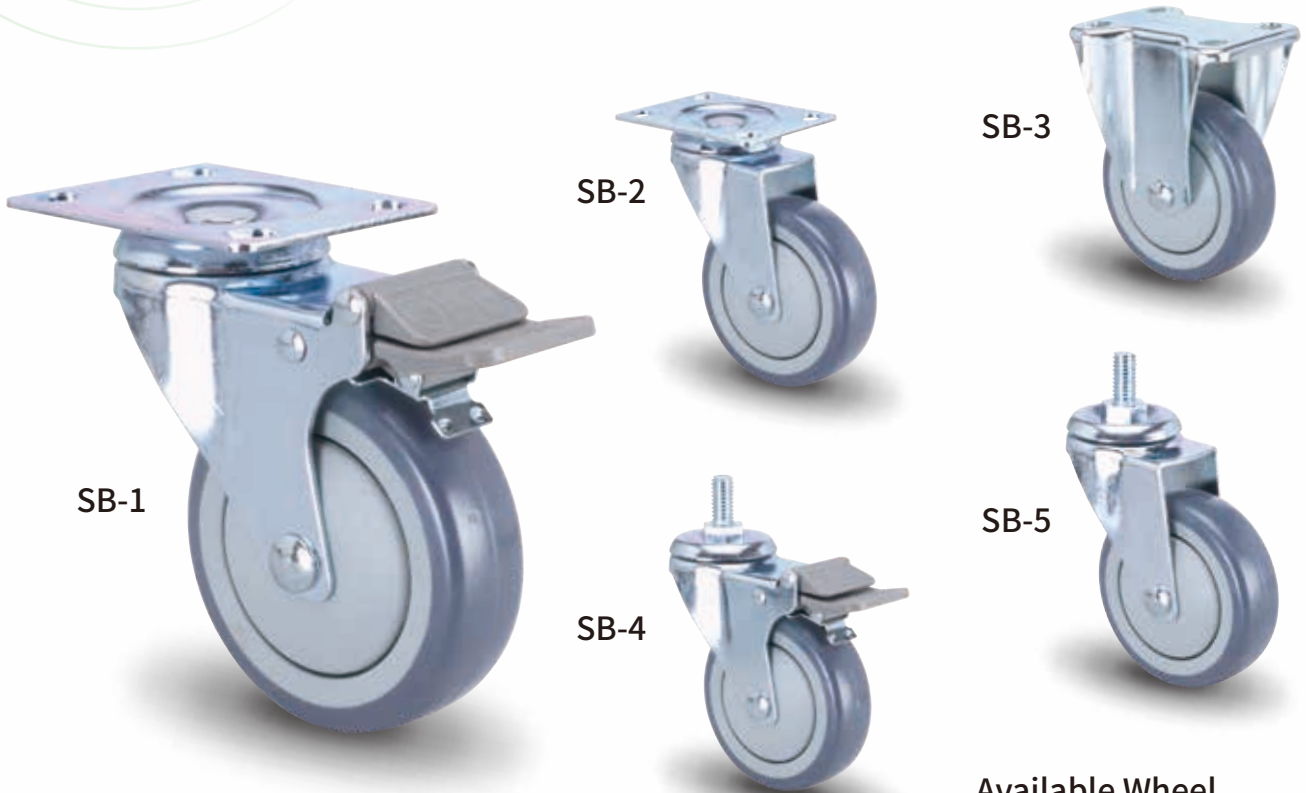

▶ 產品說明：

產品名稱：4" TPR 儀器輪

輪架結構：精密培林轉盤

輪子材質：高彈性 TPR

輪子顏色：灰、黑

適用範圍：護士推車、醫院換藥車、嬰兒床、展示櫃、角鋼、電腦機櫃、餐飲設備、食品機械設備、精密儀器設備、運輸設備、餐車、賣場推車、各式手推車

產品特點：★ 移動安靜、輕巧、不傷地板

★ 輪子兩側均有防塵蓋，防止細屑、粉塵侵入

★ 雙踏板式剎車，操作便利

Available Wheel



ESD











TPR(Bearing)



TPR(dubble bearing)



TPR

型號	 輪徑 (mm)	 輪寬 (mm)	 平板規格 (mm)	 平板孔距 (mm)	 孔徑 (mm)	 螺牙尺寸 (mm)	 總高度 (mm)	 載重量 (kg)
SB-1	100	31	93.5x75	73x49	14x10	1/2 x 25	137	80
SB-2								
SB-3								
SB-4								
SB-5								



5" TPR 儀器輪

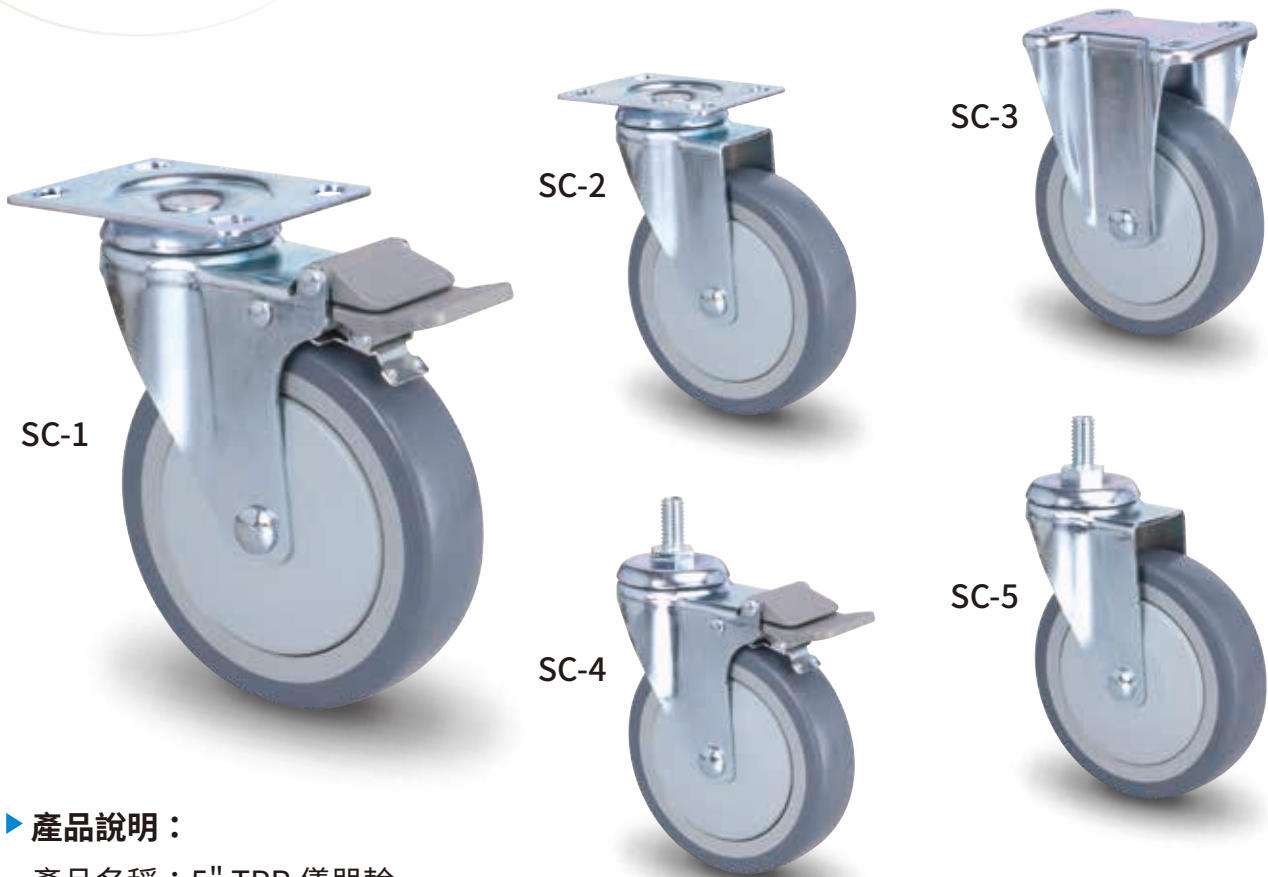

▶ 產品說明：

產品名稱：5" TPR 儀器輪

輪架結構：精密培林轉盤

輪子材質：高彈性 TPR(精密培林)

輪子顏色：灰

適用範圍：醫療儀器、醫療設備、病床、餐飲設備、食品機械設備、自動化設備、精密儀器設備、運輸設備、賣場推車

產品特點：★ 移動安靜、輕巧、不傷地板

★ 輪子兩側均有防塵蓋，防止細屑、粉塵侵入

★ 雙踏板式剎車，操作便利









Available Wheel



ESD



TPR(Bearing)

型號	 輪徑 (mm)	 輪寬 (mm)	 平板規格 (mm)	 平板孔距 (mm)	 孔徑 (mm)	 螺牙尺寸 (mm)	 總高度 (mm)	 載重量 (kg)
SC-1	125	31	93.5x75	73x49	14x10	1/2 x 25	161	100
SC-2								
SC-3								
SC-4								
SC-5								

3"、4"、5" 導電輪



▶ 產品說明：

產品名稱：3"、4"、5" 導電輪

輪架結構：精密培林轉盤

輪子材質：高彈性 TPR+ 不鏽鋼纖維 (精密培林)

輪子顏色：灰









阻 抗：10e3-10e5Ω

適用範圍：無塵室、電子廠設備

產品特點：★ 移動安靜、輕巧、行走無黑痕

★ 輪子兩側均有防塵蓋，防止細屑、粉塵侵入

★ 雙踏板式剎車，操作便利

型號	 輪徑 (mm)	 輪寬 (mm)	 平板規格 (mm)	 平板孔距 (mm)	 孔徑 (mm)	 螺牙尺寸 (mm)	 總高度 (mm)	 載重量 (kg)
ESD-3A	75	25	75.7x65	57x47	8	1/2 x 25	108	50
ESD-314	75						114	70
ESD-414	100	31	93.5x75	73x49	14x10		137	80
ESD-514	125						161	100



2" 角鋼輪

專利証號 M609973



SKY-2LB



SKY-2LW



SKY-2L



SKY-2LG

▶ 產品說明：

- 產品名稱：2" 角鋼輪
 輪架結構：鋼珠轉盤
 輪子材質：高彈性 TPR(精密培林)
 輪子顏色：灰、黑
 適用範圍：免螺絲角鋼
 產品特點：★ 輪軸採 608 單一精密培林，移動輕巧滑順、安靜、不傷地板
 ★ 輪子兩側均有防塵蓋，防止細屑、粉塵侵入
 ★ 角鋼承載座 3.5mm 厚，專利結構設計，美觀且加強支撐架載重強度，安裝便利

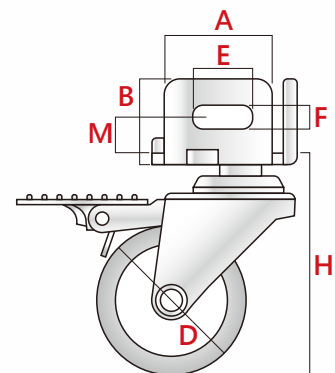

型號	Ⓓ 輪徑 (mm)	 輪寬 (mm)	Ⓐ x Ⓑ 角鋼座內尺吋 (mm)	Ⓜ 角鋼座平面至孔中心 (mm)	Ⓔ x Ⓣ 孔徑 (mm)	ⓗ 安裝高度 (mm)	 載重量 (kg)
SKY-2L	50	23	37.5x31	15	20x9	73	40
SKY-2LW						67	
SKY-2LB							
SKY-2LG							

2.5" 角鋼輪

專利証號 M609973



▶ 產品說明：

產品名稱：2.5" TPR 尼龍靜音輪

輪架結構：玻璃纖維填充尼龍腳架 + 精密培林轉盤

輪子材質：高彈性 TPR(精密培林)

輪子顏色：黑

適用範圍：免螺絲角鋼

產品特點：★ 培林轉盤設計，旋轉及移動輕巧、安靜

★ 輪架具有高度吸收衝擊的能力

★ 防水、安靜、不傷地板、美觀使用壽命長

★ 輪子側蓋有防卡毛屑設計，不會因卡毛屑而影響輪子功能

★ 角鋼承載座 3.5mm 厚，專利結構設計，美觀且加強支撐架載重強度，安裝便利

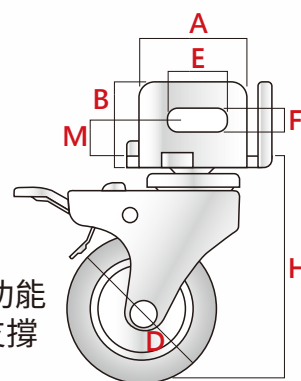

型號	Ⓓ 輪徑 (mm)	 輪寬 (mm)	Ⓐ x Ⓑ 角鋼座內尺寸 (mm)	Ⓜ 角鋼座平面至孔中心 (mm)	Ⓔ x Ⓣ 孔徑 (mm)	ⓗ 安裝高度 (mm)	 載重量 (kg)
SKY2.5LB	50	23	37.5x31	15	20x9	93.5	50
SKY2.5LG							

3" 角鋼輪

專利証號 M569657



SKY-3LB



SKY-3L

▶ 產品說明：

- 產品名稱：3" 角鋼輪
- 輪架結構：鋼珠轉盤
- 輪子材質：高彈性 TPR(精密培林)
- 輪子顏色：灰、黑
- 適用範圍：免螺絲角鋼
- 產品特點：
 - ★ 移動安靜、輕巧、不傷地板
 - ★ 專利結構設計，美觀且加強支撐架載重強度，安裝便利
 - ★ 輪子兩側均有防塵蓋，防止細屑、粉塵侵入
 - ★ 雙踏板式剎車，操作便利

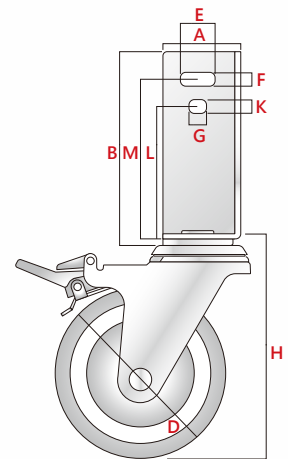

型號	Ⓓ 輪徑 (mm)	 輪寬 (mm)	Ⓑ x Ⓐ 角鋼座內尺寸 (mm)	Ⓛ & Ⓜ 角鋼座平面至孔中心 (mm)	Ⓔ x Ⓕ Ⓖ x Ⓚ 孔徑 (mm)	Ⓜ 安裝高度 (mm)	 載重量 (kg)
SKY-3L	75	31	109x42.5	83 & 98	19.5x9 & 11x9	114	80
SKY-3LB							

4" 角鋼輪

專利証號 M569657



▶ 產品說明：

- 產品名稱：4" 角鋼輪
- 輪架結構：鋼珠轉盤
- 輪子材質：高彈性 TPR(精密培林)
- 輪子顏色：灰、黑
- 適用範圍：免螺絲角鋼
- 產品特點：
 - ★ 移動安靜、輕巧、不傷地板
 - ★ 專利結構設計，美觀且加強支撐架載重強度，安裝便利
 - ★ 輪子兩側均有防塵蓋，防止細屑、粉塵侵入
 - ★ 雙踏板式剎車，操作便利

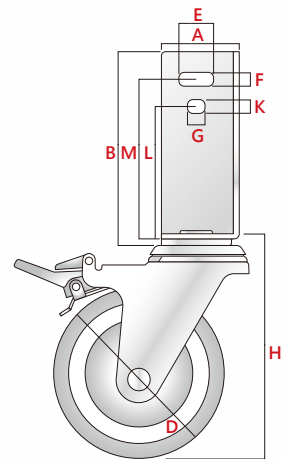

型號	Ⓓ 輪徑 (mm)	 輪寬 (mm)	Ⓑ x Ⓐ 角鋼座內尺寸 (mm)	Ⓛ & Ⓜ 角鋼座平面至孔中心 (mm)	Ⓔ x Ⓕ 孔徑 (mm)	ⓗ 安裝高度 (mm)	 載重量 (kg)
SKY-4L	100	31	109x42.5	83 & 98	19.5x9 & 11x9	138	80
SKY-4LB							
SKY-4LG							

5" 角鋼輪

專利証號 M569657



SKY-5LB



SKY-5L

▶ 產品說明：

- 產品名稱：5" 角鋼輪
- 輪架結構：鋼珠轉盤
- 輪子材質：高彈性 TPR(精密培林)
- 輪子顏色：灰、黑
- 適用範圍：免螺絲角鋼
- 產品特點：
 - ★ 移動安靜、輕巧、不傷地板
 - ★ 專利結構設計，美觀且加強支撐架載重強度，安裝便利
 - ★ 輪子兩側均有防塵蓋，防止細屑、粉塵侵入
 - ★ 雙踏板式剎車，操作便利

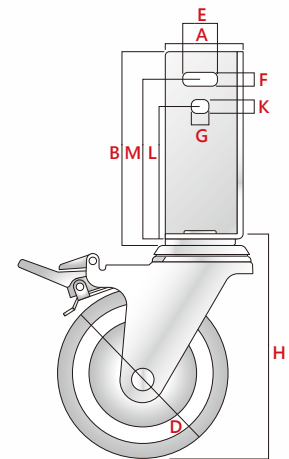

型號	Ⓓ 輪徑 (mm)	 輪寬 (mm)	Ⓑ x Ⓐ 角鋼座內尺寸 (mm)	Ⓛ & Ⓜ 角鋼座平面至孔中心 (mm)	Ⓔ x Ⓕ Ⓖ x Ⓚ 孔徑 (mm)	Ⓜ 安裝高度 (mm)	 載重量 (kg)
SKY-5L	125	31	109x42.5	83 & 98	19.5x9 & 11x9	163	80
SKY-5LB							



角鋼座調整腳

SKY-LB



SKY-LW



SKY-L



▶ 產品說明：

產品名稱：角鋼承載座 + 水平調整腳

角座顏色：黑、白、銀

適用範圍：免螺絲角鋼

產品特點：★ 專利結構設計，角鋼承載座 3.5mm 厚
(單角座可載 1000 公斤)

★ 美觀且加強支撐架載重強度，安裝便利

★ 可用於地面高低不平時調整使用

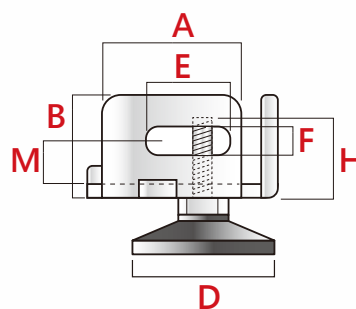

型號	Ⓓ 調整腳底盤直徑 (mm)	Ⓗ 螺牙長度 (mm)	Ⓐ x Ⓑ 角鋼座內尺寸 (mm)	Ⓜ 角鋼座平面至孔中心 (mm)	Ⓔ x Ⓕ 孔徑 (mm)	可調整高度 (mm)	Ⓚ 載重量 (kg)
SKY-L	38	25	37.5x31	15	20x9	23~40	100
SKY-LW							
SKY-LB							



調整腳



T1



T2



T3



T4



T5



T6

▶ 產品說明：

產品名稱：水平調整腳

上蓋材質：白鐵

底座材質：PP

底座顏色：灰

適用範圍：傢具設備、椅子、展示架、機械設備等

產品特點：白鐵蓋防鏽、美觀、耐重

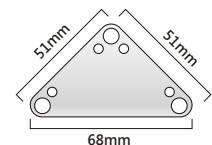
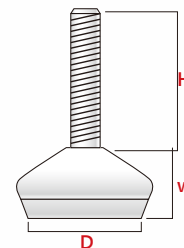

三角鐵片 厚度：2mm

型號	ⓓ 底盤 (mm)	Ⓜ 底盤厚度 (mm)	ⓗ 牙長 (mm)	螺牙規格 (mm)	KG 載重量 (kg)
T1	25	12	17、24	5/16	50
T2	25		17、24		
T3	25		17、24		
T4	30		24		
T5	30		24		
T6	30		24		

SKY CASTER



ericon.com.tw



LINE QR CODE

仲恩國際有限公司

ERICON INTERNATIONAL CO., LTD.

電話：02-2981-8089 傳真：02-2981-5368

地址：241 新北市三重區五華街 93 巷 46 號一樓

e-mail：ericonco@ms56.hinet.net

<https://www.ericon.com.tw>